

M23-M33-M43-M63 Pressure gauges with electrical contacts intrinsically safe version

M23/M33 - Differential pressure

M43 - Relative pressure with strong overpressure

M63 - Pression Absolue

Gauges with bellows Ø 150 mm

For corrosive fluids and atmospheres

Inductive contacts

Conform to ATEX 94/9/CE (EN 60079-0/EN 60079-11)

LCIE 03 ATEX 6402X

CE 0081



II 2 G

Ex ia IIA T6 or T5 or T4 Gb

Hazardous area: 1 and 2



Based upon the **MZ** (M23) - **MX** (M33) - **ME** (M43) - **MA** (M63) gauges of which they share all characteristics, they are fitted with inductive electrical contacts. They may be used in working conditions under vibrations.

Specifications (20°C)

Measurement range	See table on next page
Accuracy	± 3 %
Gauge working temperature	-20...70°C for SJ2N cell -40...70°C for SJ2SN cell <i>Classification in temperature T4-T6 of inductive contacts, see data sheet A21.33.</i> <i>Every precaution must be taken by the user to ensure that the heat transfer by the fluid to the unit head does not raise the unit head temperature to the spontaneous ignition temperature of the gas in which it is situated.</i>
Protection rating	IP 65 according NF EN 60529.
Sensing element	Two 1.4404 (AISI 316L) stainless steel bellows. Balance effect by high tensile leaf spring; mechanical start and end-of-travel stops to withstand full static pressure.
Connections and parts in contact with process fluid	In stainless steel 1.4404 (AISI 316L). Thread: G 1/2 or 1/2 NPT.
Case and bezel	1.4301 (AISI 304) Stainless steel. Bayonet lock type
Window	Transparent polycarbonate domed with watertight index adjustment knob.
Window gasket	Elastomer.
Movement	Stainless steel .
Dial	Aluminium alloy, rubber zero stop, black graduations and figures on white background.
Aiguille	Aluminium alloy, black painted
Electrical connection	Terminal block. M20x1.5 cable gland. Ø 7 to 13 mm cable.

Block diagram showing the contact block control functions:

For each independent inductive contact : U nominal 8 Vdc - electrical consumption ≥ 3mA - Ci = 30 nF, Li = 100 uH

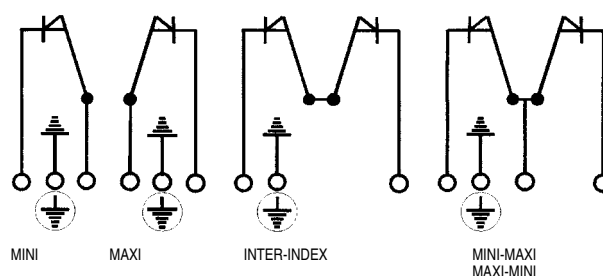

Characteristics of electrical inductive contacts and AYRA relays for ATEX: see data sheet A21.33

Options

Oxygen application **Code 0765**

Special thread ≤ G 1/2 or 1/2 NPT.

Restrictor screw **Code 0771**

Tamper proof: index adjustment **Code 0758**

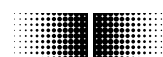

Baumer

Dimensions (mm) M23 - M33

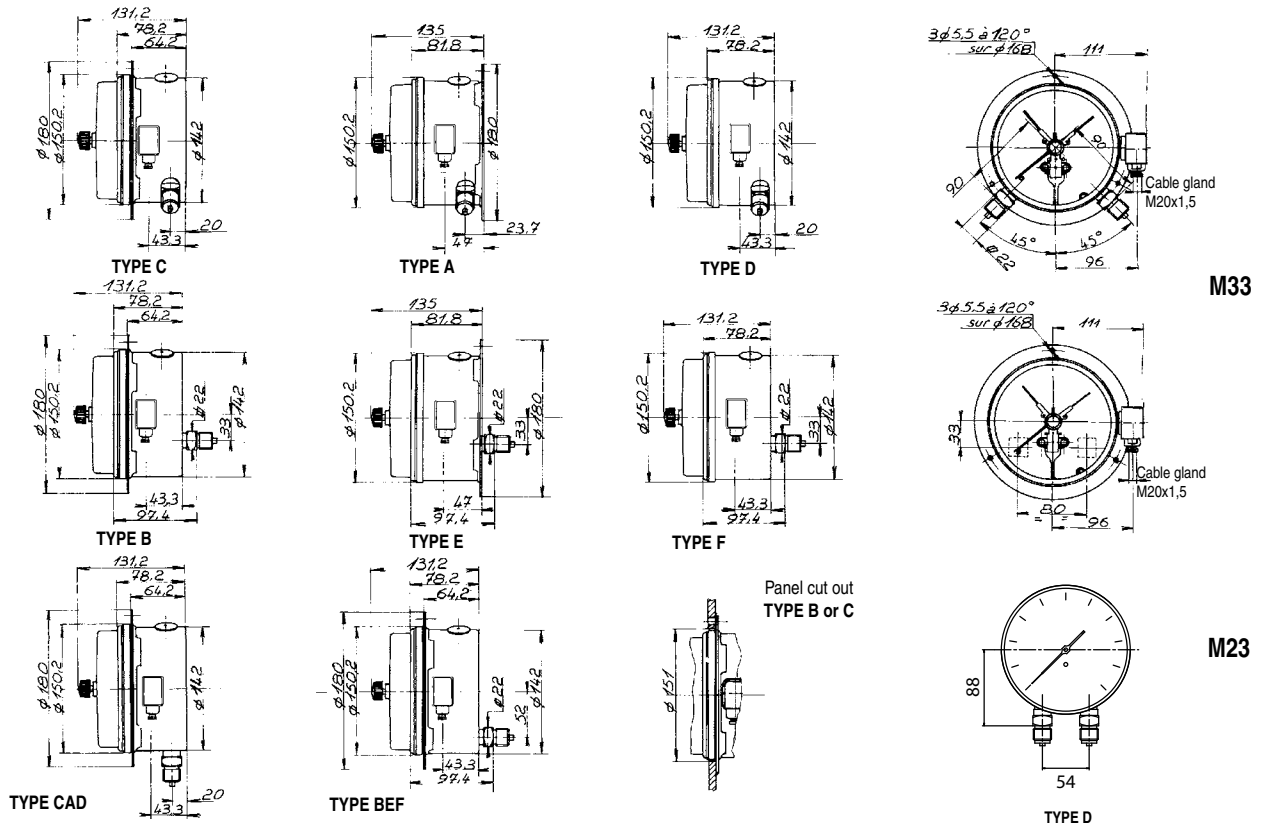

Measurement ranges (bar)

M63 (MA/CEI)

Code	Absolute pressure	Overpressure												
		0,6	1	1,6	2,5	4	6	10	16	25	40	60	100	
10	0 + 0,25	*	*	*	*	⊗	⊗	⊗	●					
11	0 + 0,4	*	*	*	*	⊗	⊗	⊗	●					
12	0 + 0,6	*	*	*	*	⊗	⊗	⊗	●					
15	0 + 1		*	*	*	*	*	⊗	⊗					
16	0 + 1,6			*	*	*	*	*	⊗	●				
18	0 + 2,5				*	*	*	*	*	⊗				
19	0 + 4					*	*	*	*	⊗	⊗			
20	0 + 6						*	*	*	*	*	●		
22	0 + 10							*	*	*	*	⊗	●	
24	0 + 16								*	*	*	*	⊗	●
	Code	A	C	D	E	F	G	H	J	K	L	M	N	

Choose an absolute pressure range, corresponding to the maximum overpressure to which the gauge will be submitted. For an intermediate overpressure, take the value of the overpressure immediately above.

M43 (ME/CEI)

Code	Relative pressure	Overpressure												
		0,6	1	1,6	2,5	4	6	10	16	25	40	60	100	
09	0 + 0,16	*	*	*	*	⊗	⊗	⊗	●					
10	0 + 0,25	*	*	*	*	⊗	⊗	⊗	●					
11	0 + 0,4	*	*	*	*	⊗	⊗	⊗	●					
12	0 + 0,6		*	*	*	*	*	⊗	⊗					
15	0 + 1			*	*	*	*	*	⊗	●				
16	0 + 1,6				*	*	*	*	*	⊗				
18	0 + 2,5					*	*	*	*	*	⊗			
19	0 + 4						*	*	*	*	*	●		
20	0 + 6							*	*	*	*	*	●	
22	0 + 10								*	*	*	*	⊗	●
	Code	A	C	D	E	F	G	H	J	K	L	M	N	

Choose a relative pressure range, corresponding to the maximum overpressure to which the gauge will be submitted. For an intermediate overpressure, take the value of the overpressure immediately above.

M23 (MZ/CEI) M33 (MX/CEI)

Code	ΔP Differential pressure	Static pressure												
		0,6	1	1,6	2,5	4	6	10	16	25	40	60	100	
10	0 + 0,25	*	*	*	*	⊗	⊗	⊗	●					
11	0 + 0,4	*	*	*	*	⊗	⊗	⊗	●					
12	0 + 0,6	*	*	*	*	⊗	⊗	⊗	●					
15	0 + 1		*	*	*	*	*	⊗	⊗					
16	0 + 1,6			*	*	*	*	*	⊗	●				
18	0 + 2,5				*	*	*	*	*	⊗				
19	0 + 4					*	*	*	*	⊗	⊗			
20	0 + 6						*	*	*	*	*	●		
22	0 + 10							*	*	*	*	⊗	●	
24	0 + 16								*	*	*	*	⊗	●
26	0 + 25									*	*	*	*	⊗
	Code	A	C	D	E	F	G	H	J	K	L	M	N	

Choose a differential pressure range ΔP, corresponding to the maximum static pressure to which the gauge will be submitted. For an intermediate static pressure, take the value of the static pressure immediately above.

Accuracy for all these pressure gauges :

- * Accuracy ± 3 % on 270°
- ⊗ Accuracy > 3 % on 270°
- ⊙ Accuracy > 3 % on 170°
- Accuracy > 3 % on 100°

Values for readings in undisturbed areas

Ordering details - M23-M33-M43-M63

		Mxxxxxxxx					
Family		1 Digit					
Pressure gauges		M					
Type		2 Digit					
M23		2					
M33		3					
M43		4					
M63		6					
Type of contacts		3 Digit					
Inductive contacts		3					
Control functions		4 Digit					
Mini (8002)	} 1 contact with sensor SJ2N	1					
Maxi (8001)		2					
Mini-Maxi (8021)	} 2 contacts with sensor SJ2N	4					
Maxi-Mini (8012)		7					
Mini (8002/8801)	} 1 contact with sensor SJ2SN	J					
Maxi (8001/8801)		L					
Mini-Maxi (8021/8801)	} 2 contacts with sensor SJ2SN	K					
Maxi-Mini (8012/8801)		N					
Type of mounting and connection position*		5 Digit					
bottom connection, back flange		A					
back connection, front flange (except M23)		B					
bottom connection, front flange		C					
bottom connection		D					
back connection, back flange (except M23)		E					
back connection (except M23)		F					
* Option Stainless steel case and bezel ring 1.4404 (316L)							
change A with 1, B with 2, C with 3, D with 4, E with 5 and F with 6							
Hydraulic connection		6 Digit					
G 1/4		2					
G1/2		3					
1/4 NPT		5					
1/2 NPT		6					
Unit of measurement		7 Digit					
bar		B					
kPa		D					
Measurement ranges		8...9 Digit					
See measurement ranges codified on tables (previous page)							xx
Static pressure or overpressure		10 Digit					
See static or overpressure scale on tables (previous page)							x

